

4. A train leaves Ebute-Meta station at 5pm and reaches Ibadan station at 10am on the same day. Another train leaves Ibadan station at 7am and reaches Ebute-Meta station at 2pm on the same day. Calculate the time at which the two trains meet?
5. The curved surface area and the total surface area of a cylinder are in ratios 1:2. If the total surface area of the cylinder is 616cm^2 . Calculate the volume of the cylinder.



**THE MATHEMATICAL ASSOCIATION
OF NIGERIA (MAN)
(LAGOS STATE)**



2022 OLYMPIAD

CATEGORY: JUNIOR

DATE: MARCH 26, 2022

TIME: 2HRS

Instructions:

1. This paper consists of two parts; PART A and PART B. Answer all the questions in each part.
2. The use of CALCULATORS or any ELECTRONIC DEVICES and STATISTICAL TABLES are not allowed.
3. Make sure your invigilator signs your answer booklet.
4. There is **NO PROVISION** for any extra answer sheet. Do not tear any part of your answer booklet.
5. Write your NAMES, your SCHOOL and your EXAMINATION number correctly on your answer booklet.
6. CLARITY, NEATNESS and ORDERLINESS are highly encouraged.
7. Check your result with your Olympiad registration pin on www.manlagosstate.com from Monday, May 23, 2022.

DO NOT OPEN UNTIL YOU ARE TOLD TO DO SO

PART A

- 1a. Find the value of $\sqrt[6]{0.000729}$ and leave your answer in standard form.
- b. Two angles are supplementary and the ratios of their angles are 1:4. What is the value of the bigger angle?
- 2a. The product of two consecutive odd numbers is 6723. What is the value of the greater number?
- b. The area of a rhombus is 216cm^2 and the length of one of its diagonal is 24cm. Find the perimeter of the rhombus in cm.
- 3a. The probability that Loyinmi will pass this exam is $\frac{4}{7}$. What is the probability of odd against him?
- b. Factorise: $4x - 64x^3$
- 4a. For what value of k does the equation has equal roots? $x^2 + 2(k - 4)x + 2k = 0$
- b. A man left $\frac{1}{7}$ th of his properties to his daughter and the remaining to be shared equally among his sons. If the share of his son doubled that of the daughter, how many sons has the man?
- 5a. Convert 111.011_{two} to number in base 10.

- b. Find the area of the shaded portion in the diagram below if $OA=35\text{cm}$ and $OB=56\text{cm}$ and angle $AOB=90^\circ$.

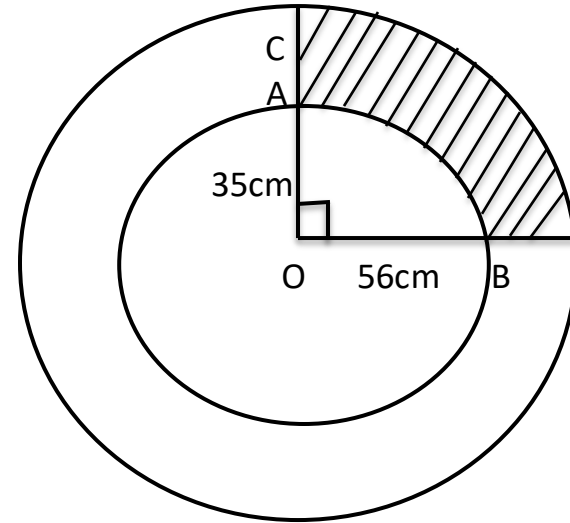
**PART B**

1. In what time will the simple interest on ₦400 at 10% per annum be the same as the simple interest on ₦1000 in 4 years at 4% per annum?
2. The quantity p varies directly as q and inversely as the square of r . When $q=7$, $r=4$ and $p=35$. Find the value of r when $p=10$ and $q=8$.
3. Make ' t ' the subject of the formula if $S = ut + \frac{1}{2}at^2$

4. The middle number of five consecutive numbers is x and the sum of all the numbers is 100. Find the numbers.

5. The sides of the rectangle in the diagram below are given in cm. Calculate the area of the triangle.

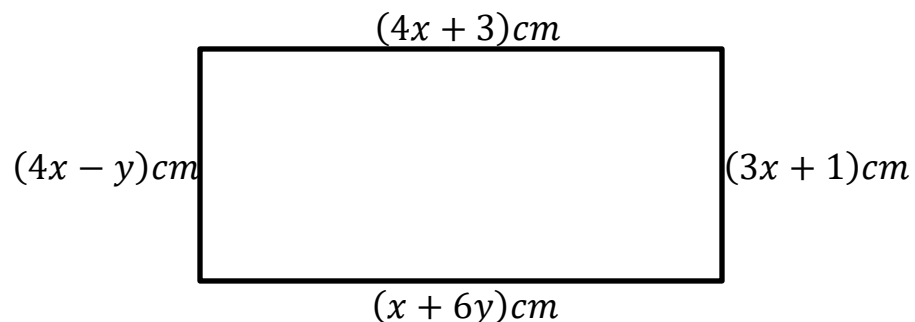

THE MATHEMATICAL ASSOCIATION
OF NIGERIA (MAN)
(LAGOS STATE)



2022 OLYMPIAD

CATEGORY: **PRIMARY**

DATE: MARCH 26, 2022

TIME: 1HR 30MINS

Instructions:

1. This paper consists of two parts; PART A and PART B. Answer all the questions in each part.
2. The use of CALCULATORS or any ELECTRONIC DEVICES and STATISTICAL TABLES are not allowed.
3. Make sure your invigilator signs your answer booklet.
4. There is NO PROVISION for any *extra* answer sheet. Do not tear any part of your answer booklet.
5. Write your NAMES, your SCHOOL and your EXAMINATION number correctly on your answer booklet.
6. CLARITY, NEATNESS and ORDERLINESS are highly encouraged.
7. Check your result with your Olympiad registration pin on www.manlagosstate.com from Monday, May 23, 2022.

DO NOT OPEN UNTIL YOU ARE TOLD TO DO SO

PART A

1a. Add the HCF and the LCM of 3, 5, 7 and 11.

b. Find the sum of all the prime numbers from 7 to 29 inclusive.

2a. If $a^2=b^2+c^2$, find the value of b when a=13 and c=12.

b. Evaluate $\left(\frac{1\frac{4}{5} - 1\frac{1}{2}}{1\frac{4}{5} + 1\frac{1}{2}} \div \frac{1}{5}\right) \times 2\frac{1}{5}$

3a. Muteeah scored an average of 58% in 3 subjects and an average score of 72% in another 4 subjects. Find his average score in all the subjects.

b. The volume of a cylinder is 3080cm^3 . If the radius of the cylinder is 7cm. Calculate its height. (Take $\pi = \frac{22}{7}$).

4a. Simplify $73.8^2 - 26.2^2$

b. If A is divided by B the result is $\frac{2}{3}$ and if B is divided by C the result is $\frac{4}{7}$. What will be the result if A is divided by C?

5a. Evaluate: $\frac{0.21 \times 1.2}{0.002}$

b. Find the value of x in the diagram below.

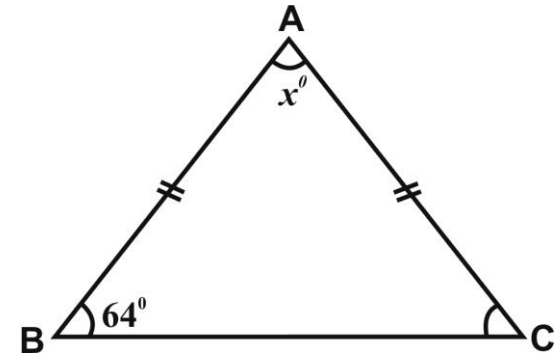

PART B

1. The sum of three positive numbers is 27. The second number is 3 more than the first number, while the third number is twice the sum of the first two numbers. Find the numbers.
2. Michael borrowed some amount of money at simple interest. The rate of interest for the first 3 years was 5%, for the next 2 years was 8% and for the next 4 years was 10%. Beyond this it was 12% per annum. If he paid N8 560.00 as an interest for 12 years, how much did he borrow?
3. When 2 is subtracted from the perimeter of a square the result is 14. Find the area of the square.

5. In the diagram below, two circles are internally tangent. A line passes through the center of the larger circle intersects it at the points A and D. The same line intersects the smaller circle at the points B and C. Given that $|AB|:|BC|:|CD| = 3:7:2$. Find the ratio of the radius of the circles.

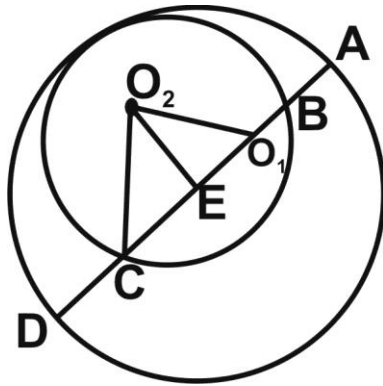

THE MATHEMATICAL ASSOCIATION
OF NIGERIA (MAN)
(LAGOS STATE)



2022 OLYMPIAD

CATEGORY: **SENIOR**
DATE: MARCH 26, 2022
TIME: 2HRS

Instructions:

1. This paper consists of two parts; PART A and PART B. Answer all the questions in each part.
2. The use of CALCULATORS or any ELECTRONIC DEVICES and STATISTICAL TABLES are not allowed.
3. Make sure your invigilator signs your answer booklet.
4. There is NO PROVISION for any extra answer sheet. Do not tear any part of your answer booklet.
5. Write your NAMES, your SCHOOL and your EXAMINATION number correctly on your answer booklet.
6. CLARITY, NEATNESS and ORDERLINESS are highly encouraged.
7. Check your result with your Olympiad registration pin on www.manlagosstate.com from Monday, May 23, 2022.

DO NOT OPEN UNTIL YOU ARE TOLD TO DO SO

PART A

1a. If the sum of the interior angles of a regular polygon is 1080° . What is the name of the polygon?

b. List the values of x in $3x - 2 \leq 10 + x < 2 + 5x$.

2a. Given that $x = \cos 30^\circ$ and $y = \sin 30^\circ$, evaluate without using tables or calculator the value of $\frac{x^2 + y^2}{y^2 - x^2}$

b. If $x = \frac{2a+3}{3a-2}$ express $\frac{x-1}{2x+1}$ in terms of a .

3a. Solve for x if

$$\log_{10}(3x + 2) - 2 \log_{10} x = 1 - \log_{10}(5x - 3)$$

3b. If $x^2 + 2x - 3x\sqrt{x} = 0$. Find the values of x .

4a. Evaluate: $\int_0^3 \frac{(x^2+2x)}{\sqrt{1+x}} dx$

b. Two students Jempeji and Biola solve an equation of the form; $x^2 + px + q = 0$. Jempeji starts with a wrong value of p and obtains the roots as 2 and 6. Biola starts with a wrong value of q and obtains the roots as 2 and -9. What are the correct values of the roots?

5a. Give that $\log_{10}(\sin x + \cos x) = -1$ and

$$\log_{10}(\sin x + \cos x) = \frac{1}{2}(\log_{10}(n - 1)).$$

Find the value of n .

b. Given that $\frac{((3!)!)!}{3!} = k \cdot n!$, where k and n are positive integers and n is as large as possible. Find the value of $k + n$.

PART B

1. If ${}^{2n+1}P_{n-1} : {}^{2n-1}P_n = 3:5$. Find the value of n .

2. Three numbers are such that their sum is 50 and their product is 3750. If the sum of their reciprocal is $\frac{31}{50}$, find the sum of the squares of the three numbers.

3. An infinite geometric series has its sum as 2005. A new series obtained by squaring each term of the original series has its sum 10 times the sum of the original series. The common ratio of the original series is $m:n$, where m and n are relatively prime positive integers. Find the value of $m+n$.

4. Prove by induction that:

$$\sum_1^n (r^3 + 3r^5) = \frac{1}{2}n^3(n+1)^3$$